

EXPLOSION PROOF FREEZER

Series Overview

The standard hazardous material storage freezer meet NFPA and OSHA guidelines for hazardous locations, Class 1, Division II, Group C & D. Engineered for use in environments where volatile or explosive conditions could potentially exist. Units are not intended for common lab or room environments that aren't designed to be explosion proof. There are no electrical components in the interior of the unit and all external components are sealed per NFPA and OSHA guidelines. Units must be hard wired in conduit to 120VAC power source. Power cords with plugs are not acceptable. *Periodic manual defrosting is required.

XPF14

The one solid swing door chamber designed for maximum capacity while still allowing passage through most commercial doorways.

Performance

Unit comes standard with a temperature range of -15° C to -25° C. Manual defrost. Products designed to operate in ambient room temperatures not to exceed 75° F / 50% RH.

Control System

All series models comes standard with a mechanical thermostat controller sealed in UL listed explosion proof box, providing a readout of actual and set-point values.

Warranties

These chambers come with a one year parts and labor warranty.



Construction

Freezer is constructed of white textured cabinet and door

- 3 fixed shelves
- One solid swing door, right hinged, not reversible
- Magnetic door gasket for positive seal with keyed door lock and heavy duty door handle
- Leveling legs
- High density urethane foam cabinet and door insulation
- CFC-free refrigerant (R134a), foam insulation and packaging
- Exterior dimensions: 29.88" W x 34.5"D x 66.5"H
- Shipping weight: 245 lbs
- Voltage: 115 / 60 / 5 Amps, 1/3 HP
- UL/C-UL listed

Hazardous Location Freezer Technical Drawings

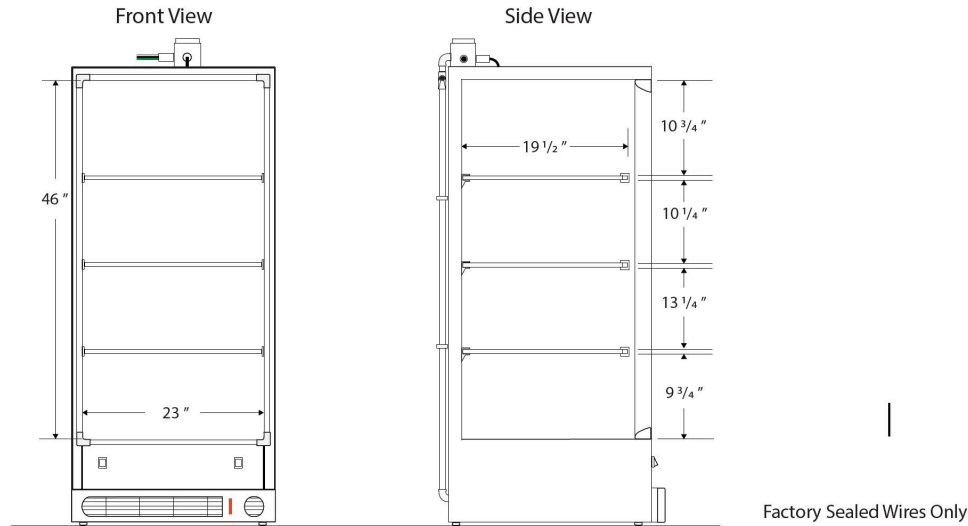

Factory Sealed Wires Only

Cu. Ft	Defrost	Door	Int Door	Shelves	Interior Dim.			Refrigerant	H.P.	Amps	Weight
					W"	D"	H"				
14	Manual	1 Solid	0	3 Fixed	23	19 1/2	46	R134a	1/3	5	185 lbs.

Note: Interior dimensions are estimates and subject to change without notice

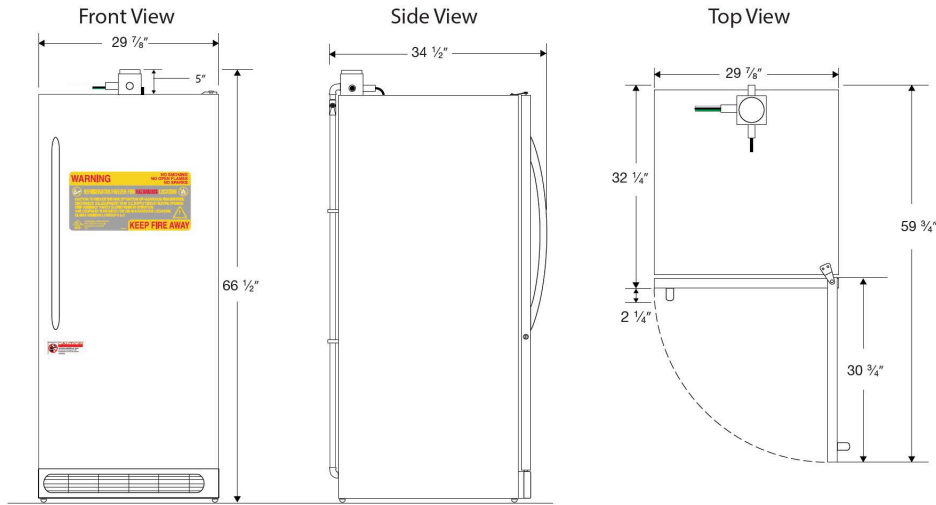

Factory Sealed Wires Only

Cu. Ft	Defrost	Door	Int Door	Shelves	Interior Dim.			Refrigerant	H.P.	Amps	Weight
					W"	D"	H"				
14	Manual	1 Solid	0	3 Fixed	29 7/8	34 1/2	66 1/2	R134a	1/3	5	185 lbs.