

# STANDARDS LABORATORY REFRIGERATORS

## Series Overview

The standard glass laboratory refrigerators are used for a variety of scientific and medical applications. The standard laboratory refrigerators feature a digital microprocessor temperature controller which allows precise management necessary for critical samples and supplies. Refrigerators have a forced air directional system which provides superior temperature uniformity and recovery after door openings.

## SLR49-GD

This laboratory refrigerator is a two-door swing glass chamber designed for maximum capacity while still allowing passage through most commercial doorways.

## Performance

Unit comes standard with a temperature range of 1° C to 10° C . Quick recovery via forced air plenum/ refrigeration system. Cycle defrost. Products designed to operate in ambient room temperatures not to exceed 75° F / 50% RH.

## Control System

All series models comes standard with a digital microprocessor controller providing a readout of actual and set-point values. This chamber comes with audible/visual alarms, high and low temperature alarms with remote alarm contacts.

## Warranties

These chambers come with a one year parts and labor warranty, plus an additional four year compressor parts warranty.



Standard Laboratory Refrigerators take a large step forward in performance from past general purpose units; offering a digital temperature display and alarm module coupled with a microprocessor temperature controller.



## Construction

Refrigerator is constructed of powder coated steel white, interior and exterior.

- 8 adjustable shelves (adjustable in 1/2" increments)
- 3/8" probe access port
- Two swing glass door, self-closing (energy efficient, double pane vacuum insulated)
- Magnetic door gasket for positive seal with keyed door lock and heavy duty door handle
- LED interior lights are safety shielded and switch controlled
- Swivel casters (3 1/2")
- High density urethane foam cabinet and insulation
- Hydrocarbon, natural refrigerant (R290)
- Exterior dimensions: 54" W x 34.75"D x 81.75"H (with casters), 54" W x 34.75"D x 78.25"H (without casters)
- Shipping weight: 538 lbs
- Voltage: 115/ 60/4.5 Amps 1/4 HP
- ETL listed
- UL/C-UL listed

## Standard Glass Door Laboratory Refrigerator Technical Drawings

Front View

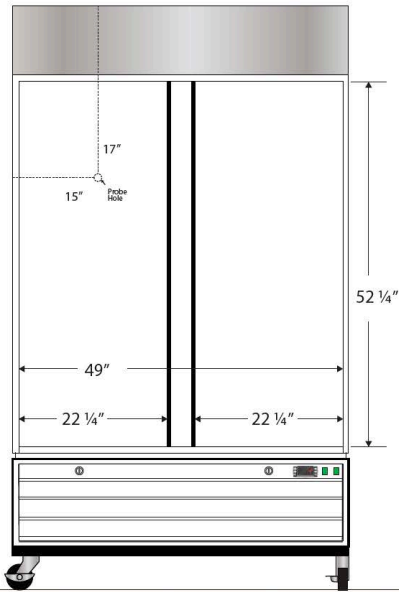

Side View

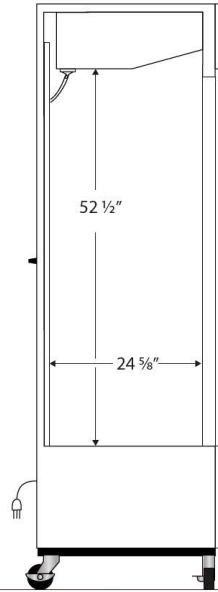

Cu. Ft	Defrost	Door	Int Door	Shelves	Interior Dim.			Refrigerant	H.P.	Amps	Weight
					W"	D"	H"				
49	Cycle	2 Glass	0	8 Adj	49	24 5/8	52 1/2	R290	1/4	4.5	488 lbs.

Note: Interior dimensions are estimates and subject to change without notice

Front View

Side View

Top View

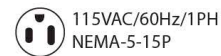
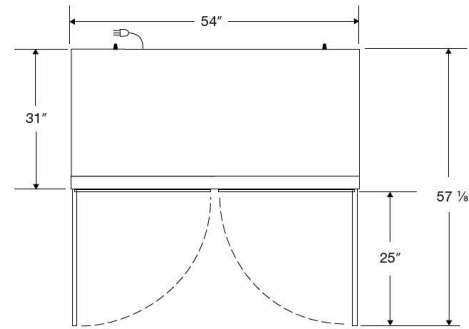

Cu. Ft	Defrost	Door	Int Door	Shelves	Interior Dim.			Refrigerant	H.P.	Amps	Weight
					W"	D"	H"				
49	Cycle	2 Glass	0	8 Adj.	54	34 3/4	81 3/4	R290	1/4	4.5	488 lbs.