

STANDARD LABORATORY REFRIGERATOR

Series Overview

The standard glass laboratory refrigerators series chambers are used for a variety of scientific and medical applications. The standard laboratory refrigerators feature a digital microprocessor temperature controller which allows precise management necessary for critical samples and supplies. Refrigerators have a forced air directional system which provides superior temperature uniformity and recovery after door openings.

SLR26-GD

This laboratory refrigerator is a single swing glass door chamber designed for maximum capacity while still allowing passage through most commercial doorways.

Performance

Units comes standard with a temperature range of 1° C to 10° C. Quick recovery via forced air plenum/ refrigeration system. Cycle defrost. Products designed to operate in ambient room temperatures not to exceed 75° F / 50% RH.

Control System

All series models comes standard with a digital microprocessor controller providing a readout of actual and set-point values. This chamber comes with audible/visual alarms, high and low temperature alarms with remote alarm contacts.

Warranties

These chambers come with a one year parts and labor warranty, plus an additional four year compressor parts warranty.



Standard Laboratory Refrigerators take a large step forward in performance from past general purpose units; offering a digital temperature display and alarm module coupled with a microprocessor temperature controller.

Construction

Laboratory refrigerator is constructed of powder coated steel white, interior and exterior.

- 4 adjustable shelves
- 3/8" probe access port
- One swing glass door, self-closing (energy efficient, double pane vacuum insulated), right hinged
- Magnetic door gasket for positive seal with keyed door lock and heavy duty door handle
- Swivel casters (3 1/2")
- LED interior lights are safety shielded and switch controlled
- High density urethane foam cabinet insulation
- Hydrocarbon, natural refrigerant (R290)
- Exterior dimensions: 28.375"W x 36.5"D x 81.75"H (with casters), 28.375" W x 36.5"D x 78.25"H (without casters)
- Shipping weight: 355 lbs
- Voltage: 115 / 60 / 3 Amps 1/5HP
- ETL listed
- UL/C-UL listed

Glass Door Laboratory Refrigerator Technical Drawings

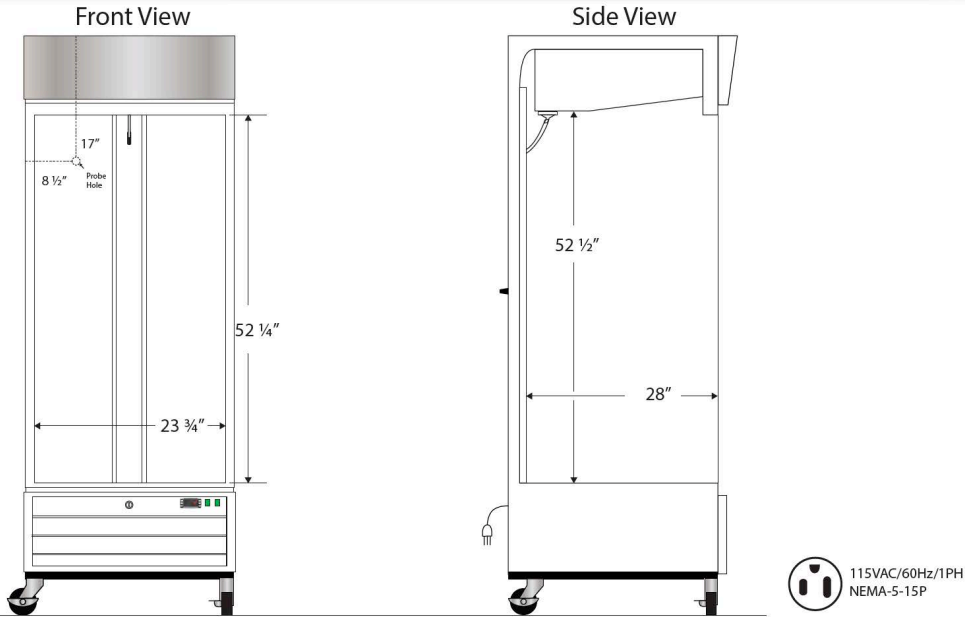

Cu. Ft	Defrost	Door	Int Door	Shelves	Interior Dim.			Refrigerant	H.P.	Amps	Weight
					W"	D"	H"				
26	Cycle	1 Glass	0	4 Adj	23 3/4	28	52 1/2	R290	1/5	3	315 lbs.

Note: Interior dimensions are estimates and subject to change without notice

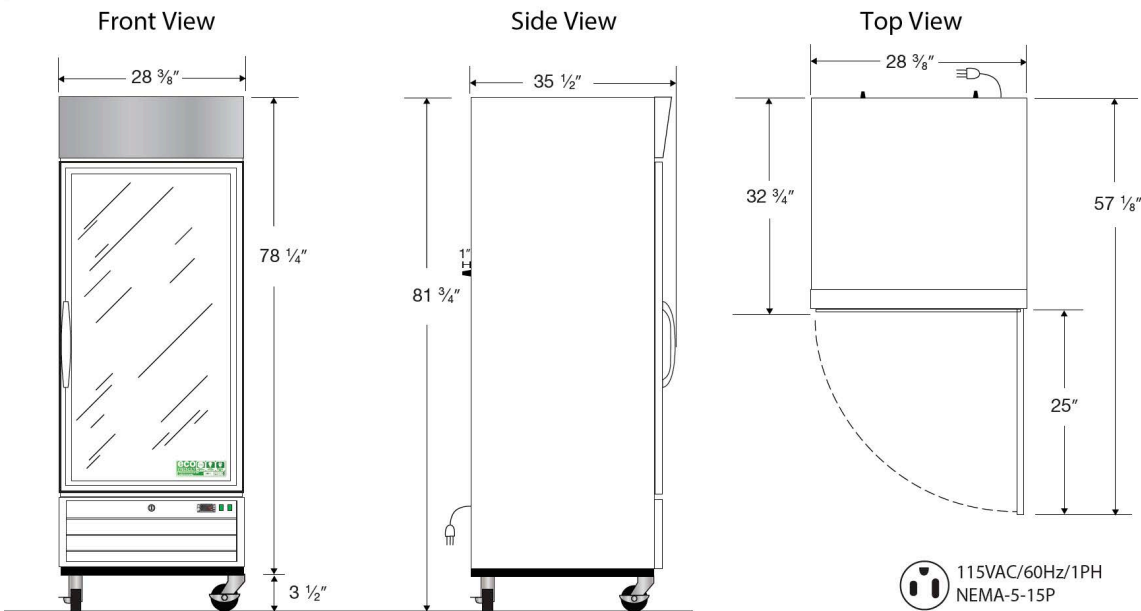

Cu. Ft	Defrost	Door	Int Door	Shelves	Interior Dim.			Refrigerant	H.P.	Amps	Weight
					W"	D"	H"				
26	Cycle	1 Glass	0	4 Adj.	28 3/8	36 1/2	81 3/4	R290	1/5	3	315 lbs.