

STANDARD LABORATORY REFRIGERATOR

Series Overview

The standard solid laboratory refrigerators are used for a variety of scientific and medical applications. The standard laboratory refrigerators feature a digital microprocessor temperature controller which allows precise management necessary for critical samples and supplies. Refrigerators have a forced air directional system which provides superior temperature uniformity and recovery after door openings.

SLR23-SD

This laboratory refrigerator is a solid swing one door chamber designed for maximum capacity while still allowing passage through most commercial doorways.

Performance

Unit comes standard with a temperature range of 1° C to 10° C. Quick recovery via forced air plenum/ refrigeration system. Cycle defrost. Products designed to operate in ambient room temperatures not to exceed 75° F / 50% RH.

Control System

All series models come standard with a digital microprocessor controller providing a readout of actual and set-point values. This chamber comes with audible/visual alarms, high and low temperature alarms with remote alarm contacts.

Warranties

These chambers come with a one year parts and labor warranty, plus an additional four year compressor parts warranty.



Standard Laboratory Refrigerators take a large step forward in performance from past general purpose units; offering a digital temperature display and alarm module coupled with a microprocessor temperature controller.



Construction

Laboratory refrigerator is constructed of powder coated steel white, interior and exterior.

- 4 adjustable shelves (adjustable in 1/2" increments)
- 3/8" probe access port
- One swing solid door, self-closing (energy efficient, double pane vacuum insulated), right hinged, not reversible
- Magnetic door gasket for positive seal with keyed door lock and heavy duty door handle
- Swivel casters (3 1/2")
- LED interior lights are safety shielded and switch controlled
- Hydrocarbon, natural refrigerant (R290)
- Exterior dimensions: 26.63" W x 34.75"D x 81.75"H (with casters), 26.63" W x 34.75"D x 78.25"H (without casters)
- Shipping weight: 250 lbs
- Voltage: 115 / 60 / 3 Amps, 1/5 HP
- ETL listed
- UL/C-UL listed

Glass Door Laboratory Refrigerator Technical Drawings

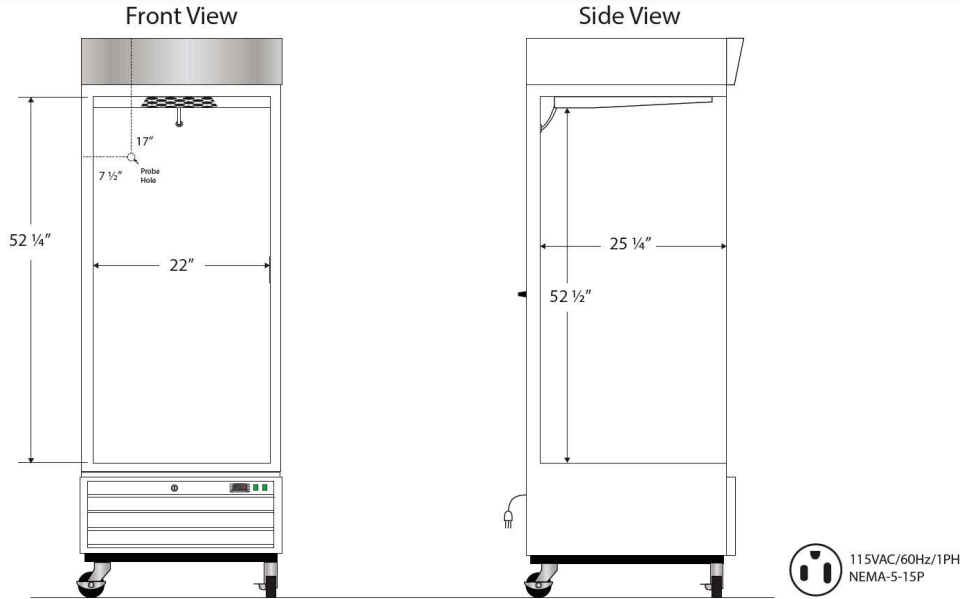

Cu. Ft	Defrost	Door	Int Door	Shelves	Interior Dim.			Refrigerant	H.P.	Amps	Weight
					W"	D"	H"				
23	Cycle	1 Solid	0	4 Adj.	22	25 1/4	52 1/2	R290	1/5	3	210 lbs.

Note: Interior dimensions are estimates and subject to change without notice.

Front View

Side View

Top View

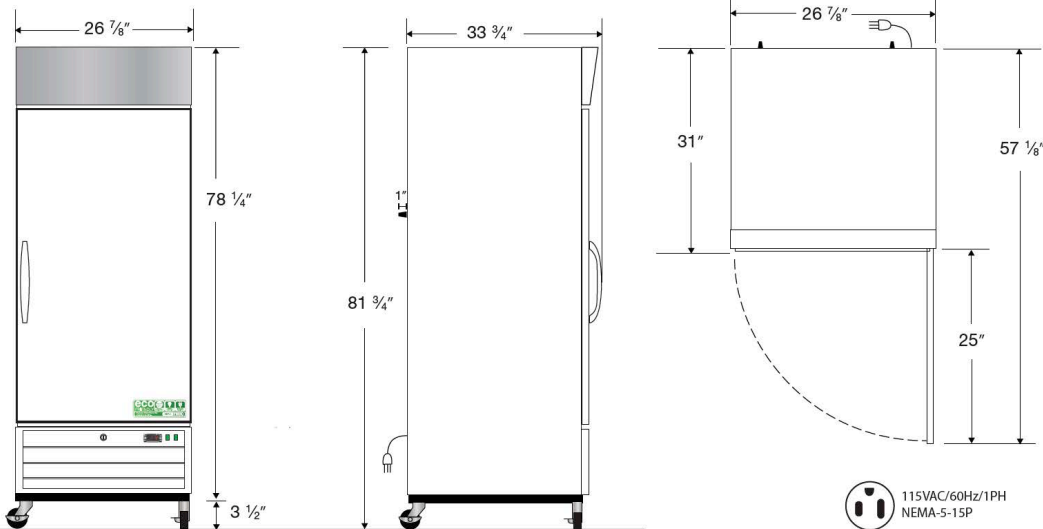

Cu. Ft	Defrost	Door	Int Door	Shelves	W"			Refrigerant	H.P.	Amps	Weight
					D"	H"					
23	Cycle	1 Solid	0	4 Adj.	26 7/8	34 3/4	81 3/4	R290	1/5	3	210 lbs.