

MANUAL DEFROST FREEZER

Series Overview

The manual defrost freezer features a microprocessor temperature controller, this allows for precise temperature control, recovery and maintenance. For critical samples and supplies they are security backed with an extensive alarm package of temperature security and alarms. Feature insulating inner doors and a manual defrost operating systems this limits product-damaging temperature spikes. The inner doors help to reduce cold air loss when the door is opened. *Periodic manual defrosting is required.

MDF30U

This freezer is a single solid swing door chamber designed for maximum capacity while still allowing passage through most commercial doorways.

Performance

Unit comes standard with a temperature range of -15°C to -25°C . Products designed to operate in ambient room temperatures not to exceed 75°F / 50% RH.

Control System

All series models comes standard with a digital microprocessor temperature controller providing a readout of actual values. This chamber comes with audible, visual, and remote alarms, with battery back-up to support temperature monitoring and alarms. Adjustable temperature display in Celsius or Fahrenheit. There is a sensor error alarm and a power failure alarm. remote monitoring and a numeric password protection. A resettable 1-point Min/Max history.

Warranties

These chambers come with a two year parts and labor warranty, plus an additional three year compressor parts warranty.



The Manual Defrost Freezers' temperature display and alarm module offer an array of robust security features with a monitoring and alarm system that is 100% independent of a microprocessor temperature controller.



Construction

Freezer is constructed of white textured cabinet and door.

- 4 fixed shelves
- 3/8" probe access port
- One solid swing door, self-closing (energy efficient, double pane vacuum insulated), right hinged, not reversible
- Magnetic door gasket for positive seal with keyed door lock and stainless steel door handle
- Five inner "fast-freeze compartments" with doors for temperature maintenance and recovery
- Caster platform (adds 4" to height)
- High density urethane foam cabinet and door insulation
- CFC-free refrigerant (R134a), foam insulation and packaging
- Exterior dimensions: 35.75" W x 34.25"D x 76.5"H (with casters), 35.75" W x 34.25" D x 72.5" H (without casters)
- Shipping weight: 462 lbs
- Voltage: 115 / 60 / 6 Amps, 1/3 HP
- UL/C- UL listed

Manual Defrost Freezer Technical Drawings

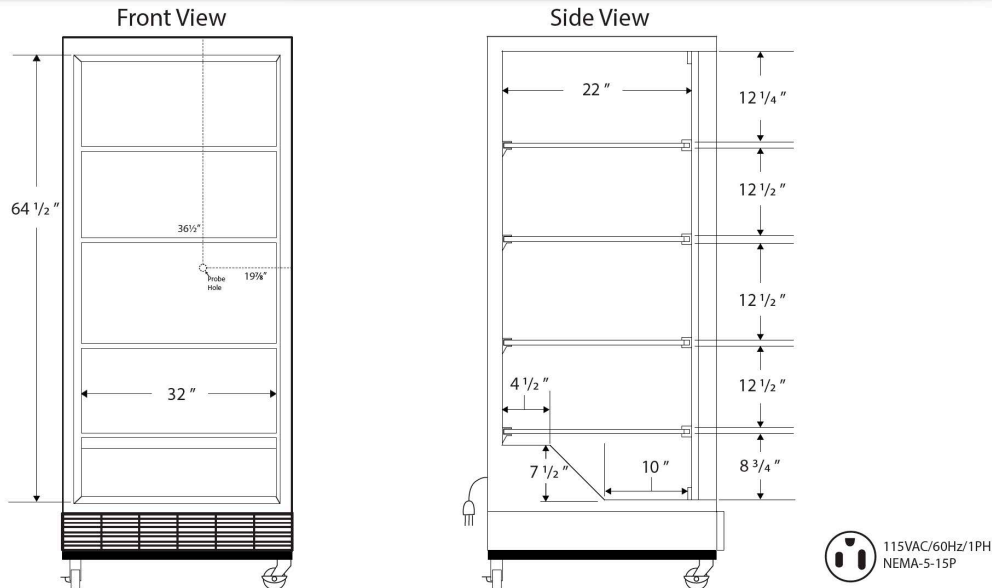

Cu. Ft	Defrost	Door	Int Door	Shelves	Interior Dim.			Refrigerant	H.P.	Amps	Weight
					W"	D"	H"				
30	Manual	1 Solid	5	4 Fixed	32	22	64 1/2	R404a	1/3	6	402 lbs.

Note: Interior dimensions are estimates and subject to change without notice

Front View

Side View

Top View

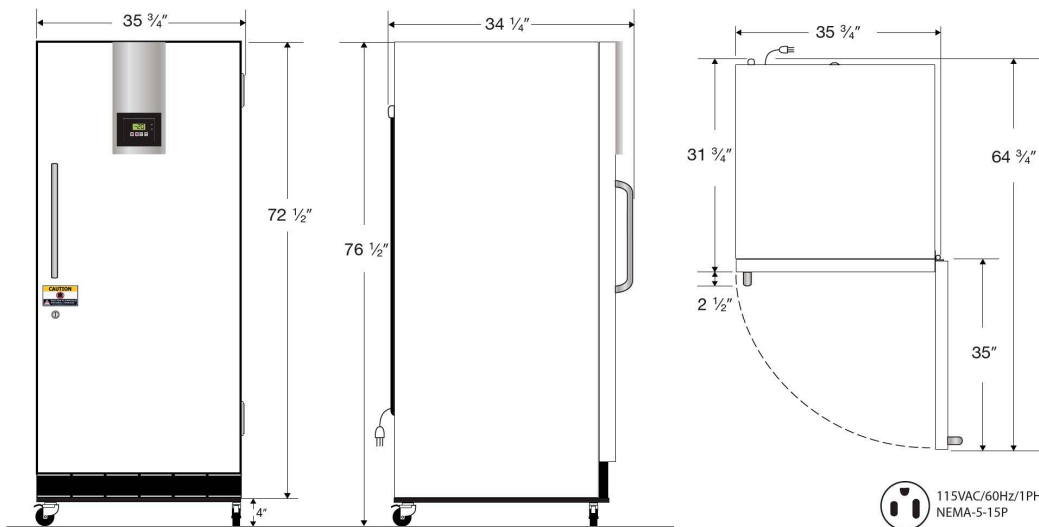

Cu. Ft	Defrost	Door	Int Door	Shelves	Interior Dim.			Refrigerant	H.P.	Amps	Weight
					W"	D"	H"				
30	Manual	1 Solid	5	4 Fixed	35 3/4	34 1/4	76 1/2	R404a	1/3	6	402 lbs.