

MANUAL DEFROST FREEZER

Series Overview

The manual defrost freezer features a microprocessor temperature controller, this allows for precise temperature control, recovery and maintenance. For critical samples and supplies they are security backed with an extensive alarm package of temperature security and alarms. *Periodic manual defrosting is required.

MDF15C

This freezer is a single solid door chamber designed for maximum capacity while still allowing passage through most commercial doorways.

Performance

Unit comes standard with a temperature range of -15° C to -25° C. Products designed to operate in ambient room temperatures not to exceed 75° F / 50% RH.

Control System

All series models comes standard with a digital microprocessor temperature controller providing a readout of actual values. This chamber comes with audible, visual, and remote alarms, with battery back-up to support temperature monitoring and alarms. Adjustable temperature display in Celsius or Fahrenheit. There is a sensor error alarm and a power failure alarm. remote monitoring and a numeric password protection. A resettable 1-point Min/Max history.

Warranties

These chambers come with a two year parts and labor warranty, plus an additional three year compressor parts warranty.



The Manual Defrost Freezers' temperature display and alarm module offer an array of robust security features with a monitoring and alarm system that is 100% independent of a microprocessor temperature controller.



Construction

Freezer is constructed of white cabinet and lid

- 2 removable baskets
- 3/8" probe access port
- One solid door, self-closing (energy efficient, double pane vacuum insulated)
- Magnetic door gasket for positive seal with keyed door lock and recessed door handle
- Swivel casters (2 3/4")
- Interchangeable leveling legs
- LED interior light
- High density urethane foam cabinet and door insulation
- CFC-free refrigerant (R134a), foam insulation and packaging
- Exterior dimensions: 56" W x 29.5"D x 35.13"H (with casters), 56" W x 29.5" D x 32.38" H (without casters), (Height with hinged door open 90° is 62 1/2")
- Shipping weight: 197 lbs
- Voltage: 115 / 60 / 5 Amps, 1/4 HP

Manual Defrost Freezer Technical Drawings

Front View

Side View

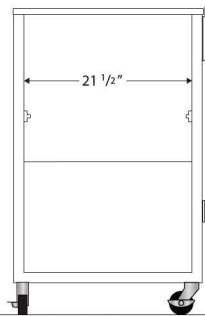
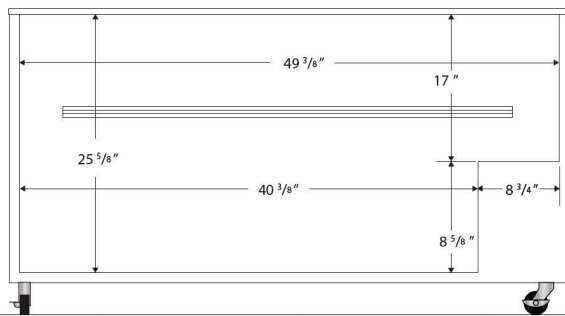
 115VAC/60Hz/1PH
NEMA-5-15P

Cu. Ft	Defrost	Door	Int Door	Shelves	Interior Dim.			Refrigerant	H.P.	Amps	Weight
					W"	D"	H"				
15	Manual	1 Solid	0	2 Baskets	49 3/8	21 1/2	25 5/8	R134a	1/4	5	137 lbs.

Note: Interior dimensions are estimates and subject to change without notice

Front View

Side View

Top View

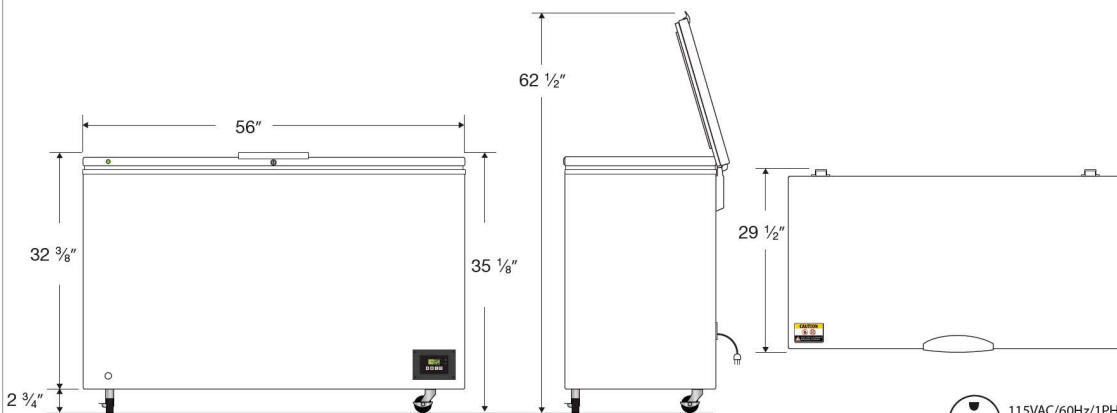
 115VAC/60Hz/1PH
NEMA-5-15P

Cu. Ft	Defrost	Door	Int Door	Shelves	Interior Dim.			Refrigerant	H.P.	Amps	Weight
					W"	D"	H"				
15	Manual	1 Solid	0	2 Baskets	56	29 1/2	35 1/8	R134a	1/4	5	137 lbs.