

HTX09 HIGH HEAT INCUBATOR/OVEN

HTX Series Overview

The HTX series chambers are designed for performance while utilizing heat. All HTX series chambers incorporate simple serviceability and excellent reliability.



Featured photo is the HTX09 benchtop high heat incubator/oven featured upgraded West controller, open door view to show adjustable internal racks.

Specifications:

- Temperature Range: 40°C to 150°C
- Control of temperature at sensor: 0.55°C
- Temperature sensor accuracy: $\pm 0.55^\circ\text{C}$

Temperature control and uniformity specifications assume standard operation in a controlled ambient condition of 72°F $\pm 8^\circ\text{F}$ and a dew-point at or below 52°F (72°F/50% RH).

Features: The HTX series boasts an efficient heat distribution system to provide optimal performance. Heated air is engineered to flow in an umbrella pattern, ensuring increased uniformity. Chamber is equipped with automatic high temperature cut-off to protect contents and user, and an easily serviceable heater and fan unit.

Controls: All controls/instrumentation and sensors are calibrated to NIST traceable standards. Chamber features non-proprietary Fuji microprocessor controller with PID, auto tuning, programmable (hi/lo) alarms, ability to ramp/soak, process and set-point variable offsets, and dual display of actual and set-point temperature. Controller is able to be quickly exchanged for future upgrades or repair.

Includes: Two adjustable shelves, lockable low-profile caster wheels, 9' power cord, and operations manual on USB drive.

Construction: Corrosion-resistant 304 series stainless steel interior and door liner. Heavy-gauge, powder-coated, galvanized steel exterior sides/exposed surfaces; powder-coated aluminum door exterior. Chamber has one hinged door with latch. Internal dimensions: 29.75"W x 23"D x 27.75"H. External dimensions: 34.5"W x 27.5"D x 44.25"H

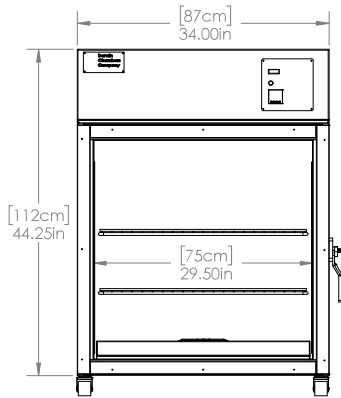

FRONT VIEW
(DOOR REMOVED)

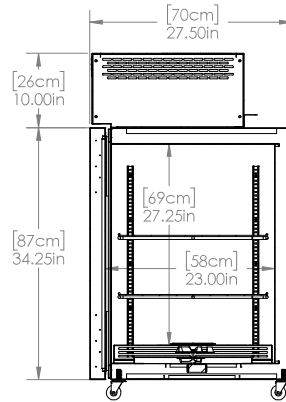

SIDE VIEW
(SECTION)

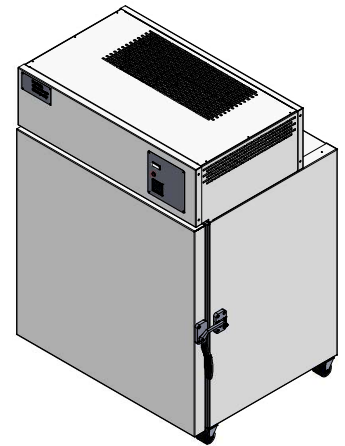

3D VIEW

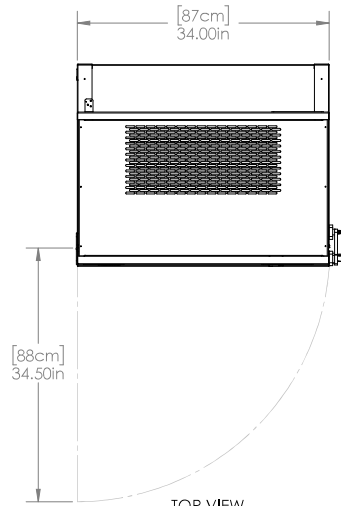

TOP VIEW

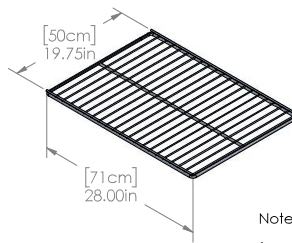

WIRE SHELF

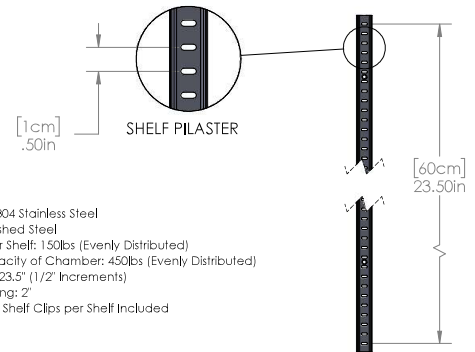

SHELF PILASTER

Notes:

- Shelf Material: 304 Stainless Steel
- Shelf Finish: Polished Steel
- Max Weight per Shelf: 150lbs (Evenly Distributed)
- Max Load Capacity of Chamber: 450lbs (Evenly Distributed)
- Pilaster Height: 23.5" (1/2" Increments)
- Minimum Spacing: 2"
- 4 Stainless Steel Shelf Clips per Shelf Included

Note: Tolerances are 0.25" unless otherwise stated.
*Dimensions and components are subject to change without notice.