

## GENERAL PURPOSE REFRIGERATOR

### Series Overview

The general purpose refrigerator is intended for general purpose applications where precision of microprocessor temperature controller is not required. Not intended for high value laboratory supplies, biologicals and pharmaceuticals that require precise temperature controls, maintenance and monitoring displays/alarms. Auto defrost have an electric heater on the evaporator that helps in the removal of frost and ice, but it can lead to rises in temperature. Require 4" clearance around back and sides for proper ventilation.

### GPR-30

One solid swing door chamber designed for maximum capacity while still allowing passage through most commercial doorways.

### Performance

Unit comes standard with a temperature range of 1° C to 10° C. Auto defrost. Products designed to operate in ambient room temperatures not to exceed 75° F / 50% RH.

### Control System

All series models comes standard with a mechanical thermostat controller.

### Warranties

These chambers come with a two year parts and labor warranty, plus an additional three year compressor parts warranty.



### Construction

Refrigerator is constructed of white textured cabinet and door.

- 5 adjustable shelves
- one solid swing doors, right hinged, not reversible
- Magnetic door gasket for positive seal with keyed door lock and stainless steel door handle
- Leveling legs
- Probe access port (3/8")
- High density urethane foam cabinet and door insulation
- CFC-free refrigerant (R134a), foam insulation and packaging
- Exterior dimensions: 35.75"W x 35 "D x 72.5 "H
- Shipping weight: 396 lbs
- Voltage: 115/60/ 6.8 Amps, 1/3 HP
- UL/C-UL listed

## General Purpose Refrigerator Technical Drawings

Front View

Side View

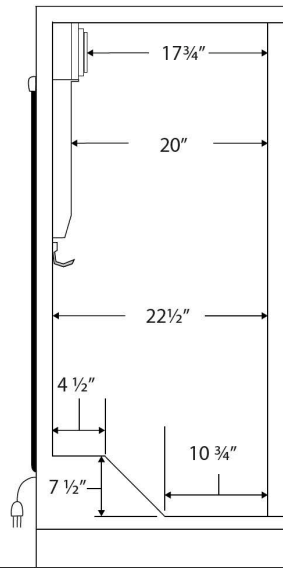
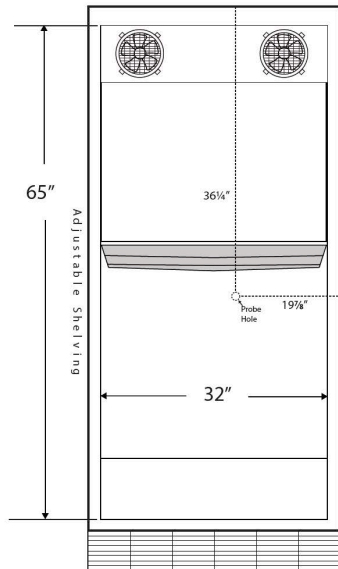

Cu. Ft	Defrost	Door	Int Door	Shelves	Interior Dim.			Refrigerant	H.P.	Amps	Weight
					W"	D"	H"				
30	Cycle	1 Solid	0	5 Adj.	32	22 1/2	65	R404a	1/3	6.8	312 lbs.

Note: Interior dimensions are estimates and subject to change without notice

Front View

Side View

Top View

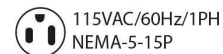
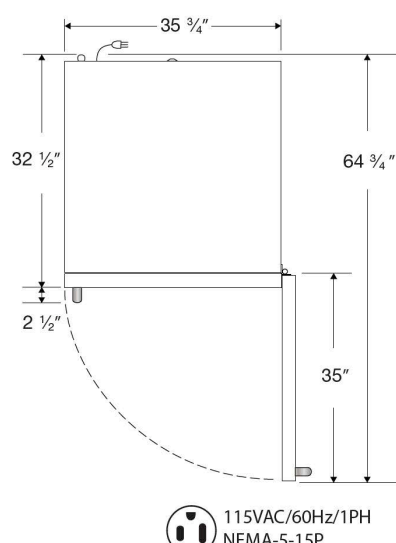
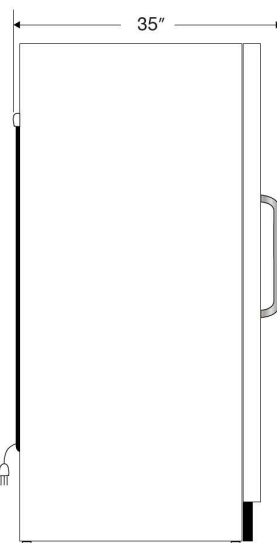
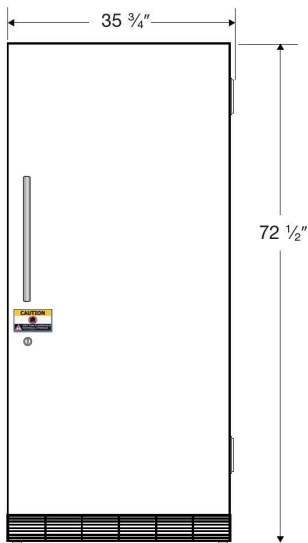

Cu. Ft	Defrost	Door	Int Door	Shelves	Interior Dim.			Refrigerant	H.P.	Amps	Weight
					W"	D"	H"				
30	Cycle	1 Solid	0	5 Adj.	35 3/4	35	72 1/2	R404a	1/3	6.8	340 lbs.