

GENERAL PURPOSE MANUAL DEFROST FREEZER

Series Overview

The manual defrost freezers are for general purpose applications where temperature control that needs to be precise is not essential. Designed to operate without product damaging auto defrost cycles. *Periodic manual defrosting is required

GPMDF-15C

This freezer is a single solid door chamber designed for maximum capacity while still allowing passage through most commercial doorways.

Performance

Unit comes standard with a temperature range of -15°C to -25°C . Products designed to operate in ambient room temperatures not to exceed 75°F / 50% RH.

Control System

All series models comes standard with a mechanical thermostat

Warranties

These chambers come with a one year parts and labor warranty, plus an additional four year compressor parts warranty.



Construction

Freezer is constructed of white cabinet and lid

- 2 removable baskets
- 3/8" probe access port
- One solid door, self-closing (energy efficient, double pane vacuum insulated)
- Magnetic door gasket for positive seal with keyed door lock
- Swivel casters (2 3/4")
- LED interior light
- High density urethane foam cabinet and door insulation
- CFC-free refrigerant (R134a), foam insulation and packaging
- Exterior dimensions: 56" W x 29.5"D x 35.13"H (with casters), 56" W x 29.5"D x 32.38" H (without casters), (Height with hinged door open 90° is 62 1/2")
- Shipping weight: 197 lbs
- Voltage: 115 / 60 / 5 Amps, 1/4 HP
- Manual defrost

Manual Defrost Freezer Technical Drawings

Front View

Side View

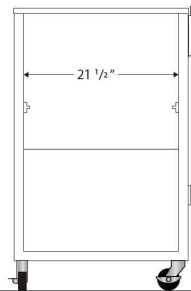
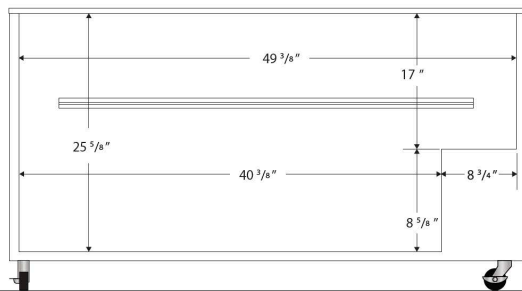

Cu. Ft	Defrost	Door	Int Door	Shelves	Interior Dim.			Refrigerant	H.P.	Amps	Weight
					W"	D"	H"				
15	Manual	1 Solid	0	2 Baskets	49 3/8	21 1/2	25 3/8	R134a	1/4	5	137 lbs.

Note: Interior dimensions are estimates and subject to change without notice

Front View

Side View

Top View

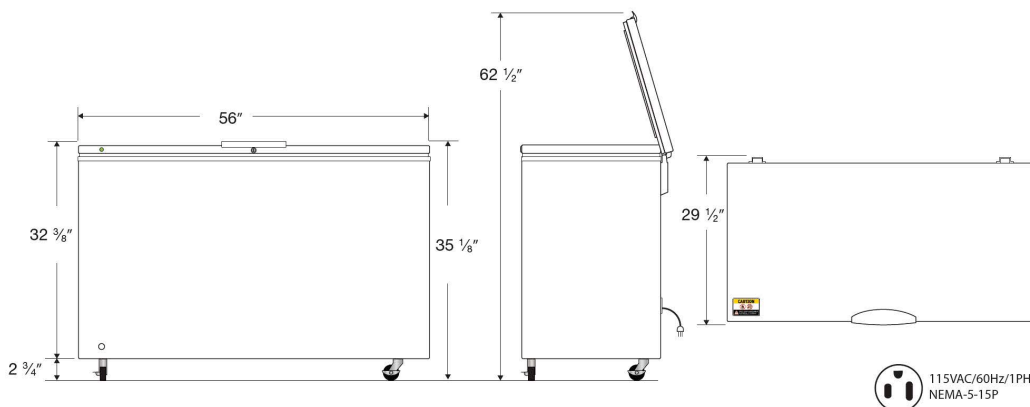

Cu. Ft	Defrost	Door	Int Door	Shelves	W"	D"	H"	Refrigerant	H.P.	Amps	Weight
15	Manual	1 Solid	0	2 Baskets	56	29 1/2	35 1/8	R134a	1/4	5	137 lbs.