

FREESTANDING UNDERCOUNTER REFRIGERATOR

Series Overview

The freestanding countertop refrigerator features a microprocessor temperature controller and display. This allows for precise temperature control, verification and recovery. An interior fan, forced-draft air circulation system is used and provides temperature uniformity when the door is opened. Temperature display and alarm offers product security. Units require 4" of clearance around the back and sides of the unit for ventilation.

FSUR-0204

One solid swing door chamber designed for maximum capacity while still allowing passage through most commercial doorways.

Performance

Unit comes standard with a temperature range of 1° C to 10° C. Cycle defrost. Products designed to operate in ambient room temperatures not to exceed 75° F / 50% RH.

Control System

All series models come standard with a digital microprocessor temperature controller providing a readout of actual and set-point values. This chamber comes with audible/visual alarms, high and low temperature alarms with remote alarm contacts.

Warranties

These chambers come with a two year parts and labor warranty.



The Premier Freestanding Undercounter Refrigerators & Freezers take a large step forward in performance from past general purpose units; offering a digital temperature display and alarm module coupled with a microprocessor temperature controller.



Construction

Refrigerator is constructed of a powder coated exterior.

- 4 adjustable shelves (two large, two small) with guard rail to prevent product from being pushed against back wall
- One solid swing door, right hinged, not reversible
- Magnetic door gasket for positive seal with keyed door lock and integrated door handle
- Leveling legs
- Back wall evaporator cover
- Probe access port (3/8")
- High density urethane foam cabinet and door insulation
- HFC-free refrigerant (R600a), foam insulation and packaging
- Exterior dimensions: 17.75" W x 19.5"D x 28.88"H
- Shipping weight: 85 lbs
- Voltage: 115 / 60 / .90 Amps, 1/8 HP
- Energy consumption: 0.58 kWh/day
- ADA compliant
- UL/C-UL listed
- Pyxis®, Omnicell® and AcuDose RX® compatible
- Energy Star Certified

Countertop Freestanding Refrigerator Technical Drawings

Front View

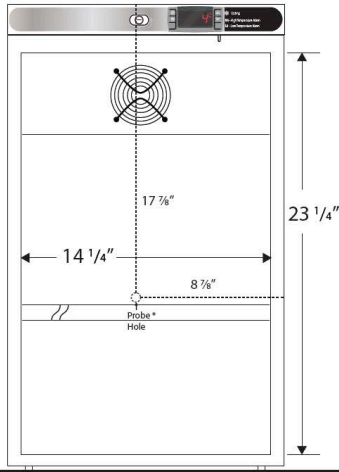

Side View

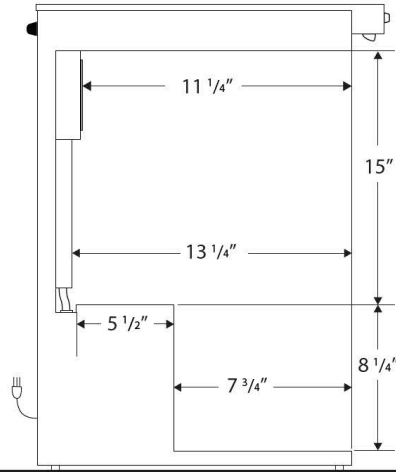

Cu. Ft	Defrost	Door	Int Door	Shelves	Interior Dim.			Refrigerant	H.P.	Amps	Weight
					W"	D"	H"				
2.5	Cycle	1 Solid	0	4 Adj	14 1/4	13 1/4	23 1/4	R600a	1/8	.90	68 lbs.

Note: Interior dimensions are estimates and subject to change without notice.

Front View

Side View

Top View

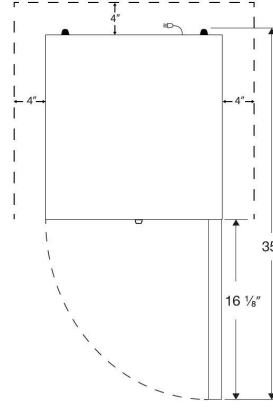
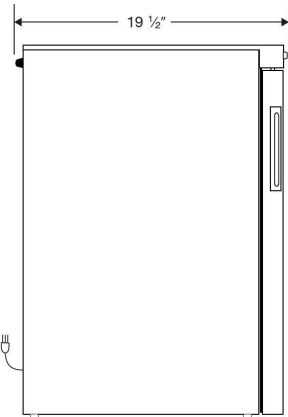
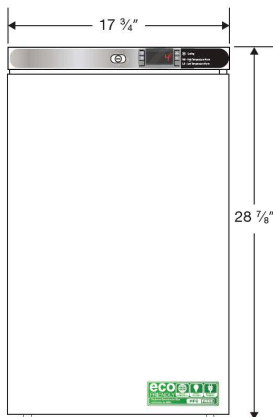

NOTE: Ventilation Requirements – Minimum 4" clearance on sides and back



Cu. Ft	Defrost	Door	Int Door	Shelves	W"	D"	H"	Refrigerant	H.P.	Amps	Weight
2.5	Cycle	1 Solid	0	4 Adj	17 3/4	19 1/2	28 7/8	R600a	1/8	.90	68 lbs.