

FREESTANDING UNDERCOUNTER FREEZER

Series Overview

The freestanding countertop freezer features a microprocessor temperature controller and display. This allows for precise temperature control, verification and recovery. Temperature display and alarm offers product security. Units require 4" of clearance around the back and sides of the unit for ventilation. *Periodic manual defrosting is required

FSUF-0120

One solid swing door chamber designed for maximum capacity while still allowing passage through most commercial doorways.



The Premier Freestanding Undercounter Refrigerators & Freezers take a large step forward in performance from past general purpose units; offering a digital temperature display and alarm module coupled with a microprocessor temperature controller.



Performance

Unit comes standard with a temperature range of -15° C to -25° C. Manual defrost. Products designed to operate in ambient room temperatures not to exceed 75° F / 50% RH.

Control System

All series models come standard with a digital microprocessor temperature controller providing a readout of actual and set-point values. This chamber comes with audible/visual alarms, high and low temperature alarms with remote alarm contacts.

Warranties

These chambers come with a two year parts and labor warranty.

Construction

Freezer is constructed of a powder coated exterior.

- 2 adjustable shelves with guard rail to prevent product from being pushed against back wall
- One solid swing door, right hinged
- Magnetic door gasket for positive seal with keyed door lock and integrated door handle
- Leveling legs
- Bottom footed shelf to allow air circulation
- LED interior light
- Probe access port (3/8")
- High density urethane foam cabinet and door insulation
- HFC-free refrigerant (R600a), foam insulation and packaging
- Exterior dimensions: 23.75" W x 24"D x 20.38"H
- Shipping weight: 106 lbs
- Voltage: 115 / 60 / 1 Amps, 1/8 HP
- UL/C-UL listed
- Pyxis®, Omnicell® and AcuDose RX® compatible
- Energy Star Certified

Countertop Freestanding Freezer Technical Drawings

Front View

Side View

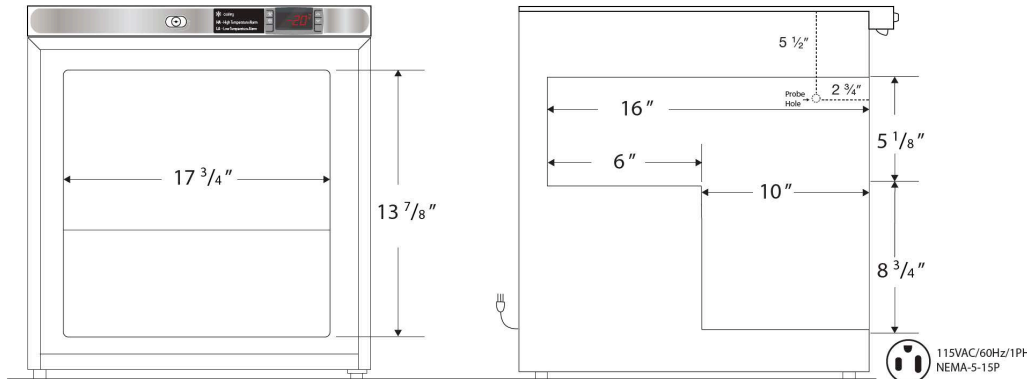

Cu. Ft	Defrost	Door	Int Door	Shelves	Interior Dim.			Refrigerant	H.P.	Amps	Weight
					W"	D"	H"				
1.7	Manual	1 Solid	0	2 Adj +Footed Bottom	17 3/4	16	13 7/8	R600a	1/8	1	80 lbs.

Note: Interior dimensions are estimates and subject to change without notice

Front View

Side View

Top View

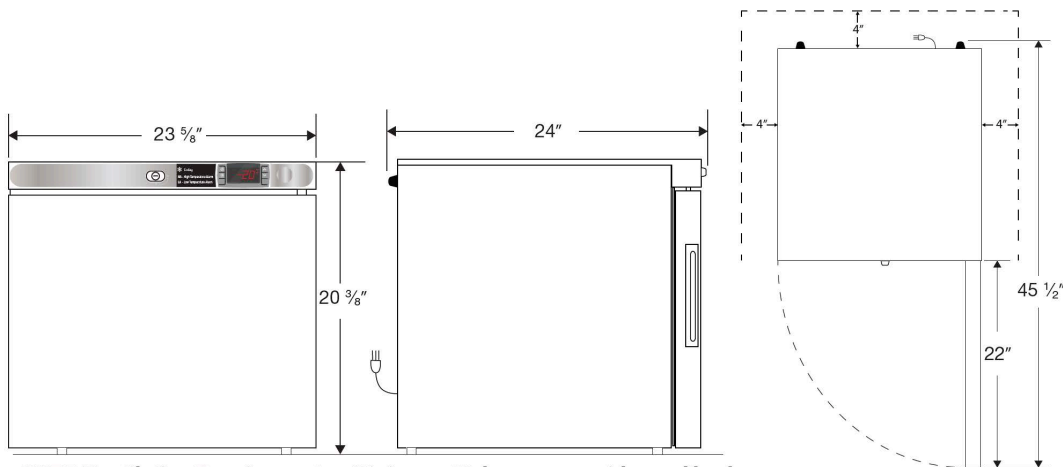

NOTE: Ventilation Requirements - Minimum 4" clearance on sides and back

115VAC/60Hz/1PH
NEMA-5-15P

Cu. Ft	Defrost	Door	Int Door	Shelves	W"	D"	H"	Refrigerant	H.P.	Amps	Weight