

PG011 Chamber

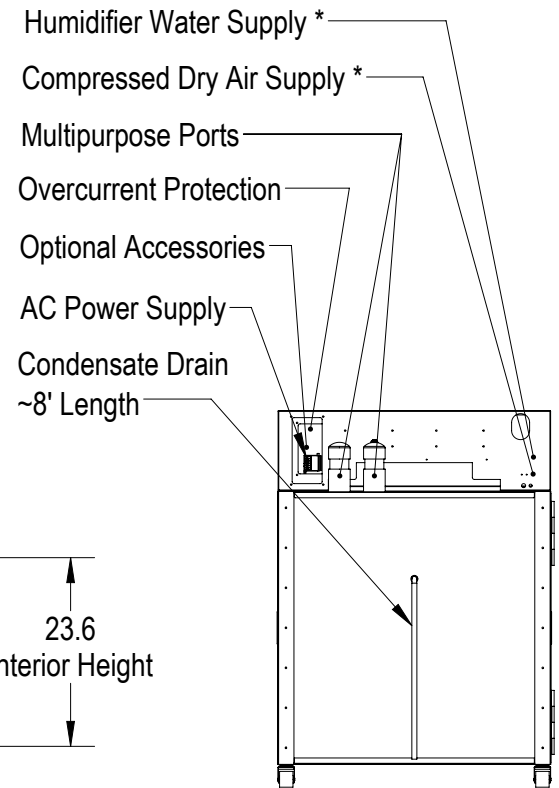

2.9 Caster Height

2in Access Port
(1) Each Side

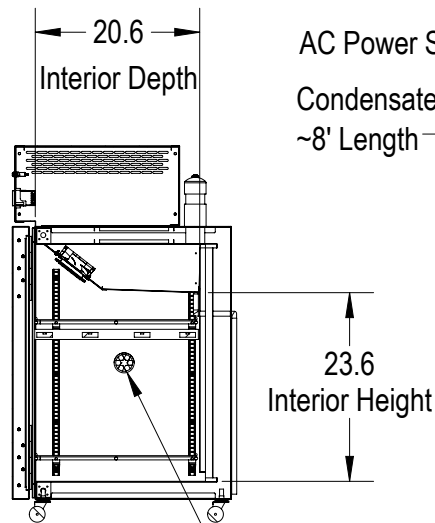
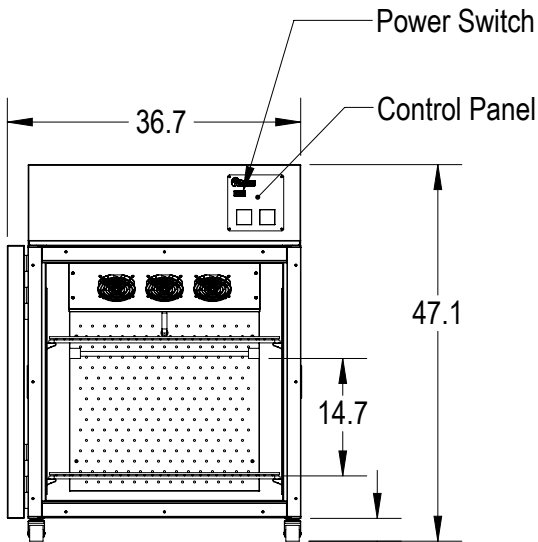
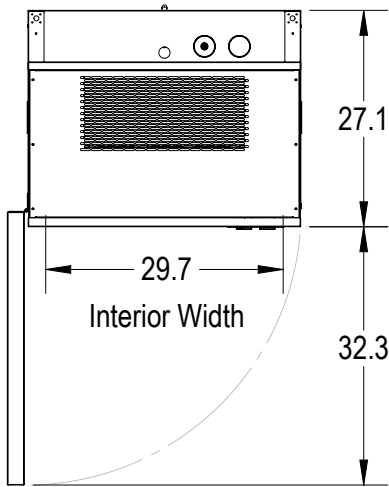
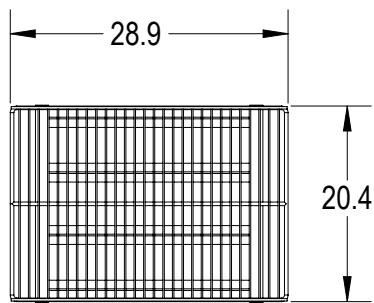

304 Stainless Steel Wire Shelf
With LED Plant Growth Light Fixture
(2) Included

* Optional Accessory

Notes:

- Crated Weight: 470lbs.
- Shelves adjustable in 1/2" increments. Minimum 2" spacing required.
- Weight Capacity: 150lbs per shelf.
- Dimensions and components are subject to change without notice.
- Some options may affect chamber performance.