

Dimensions in Inches
Unless Otherwise Specified

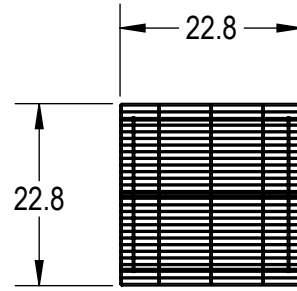
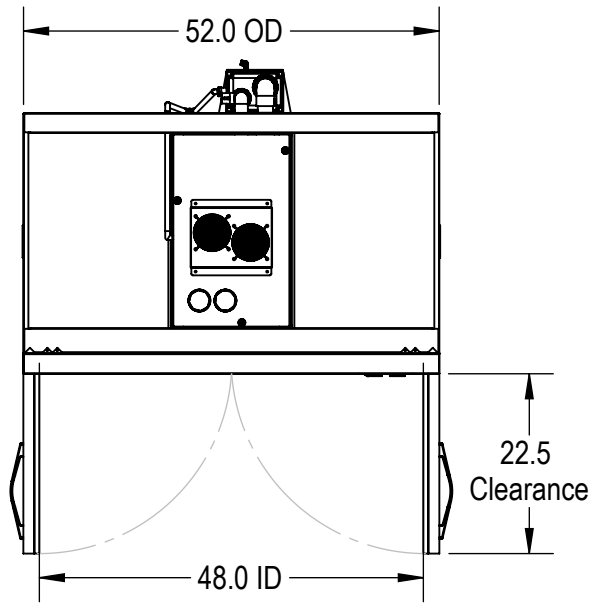

Wire Shelf (X6)

Notes:

- Shelves adjustable in 1/2" increments. Minimum 2" spacing required
- Weight Capacity: 90 lbs per shelf
- Minimum Door Width Clearance: 34.5"
- Dimensions and components are subject to change without notice.
- Some options may affect chamber performance.

Removable for low clearance

3.9

Power Switch
Control Panel

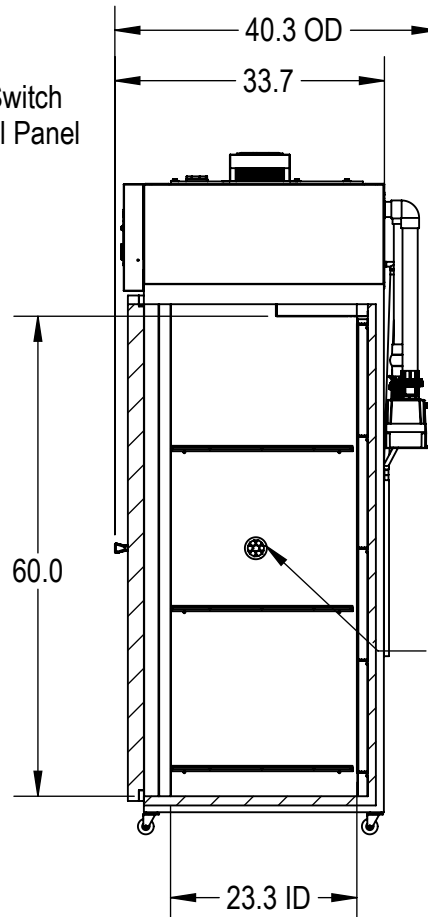
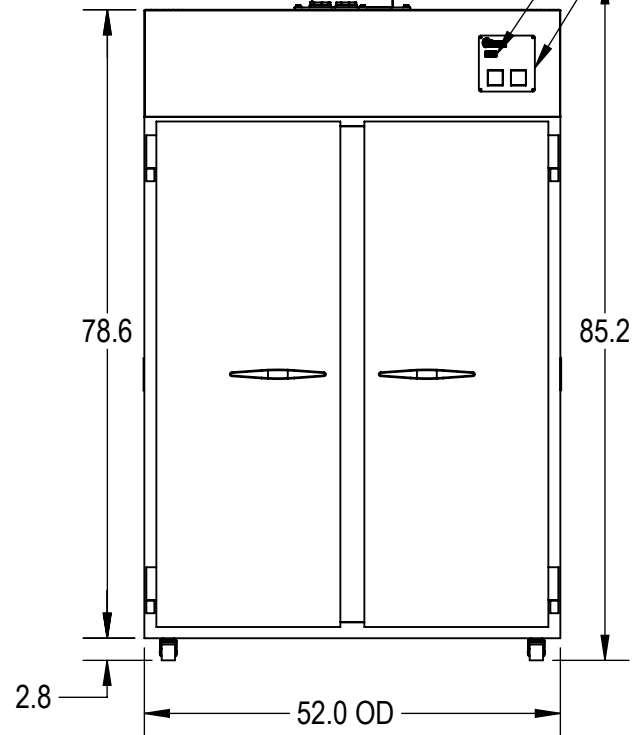

Access Port
Ø 2
(1) each side

Drain Line
8ft

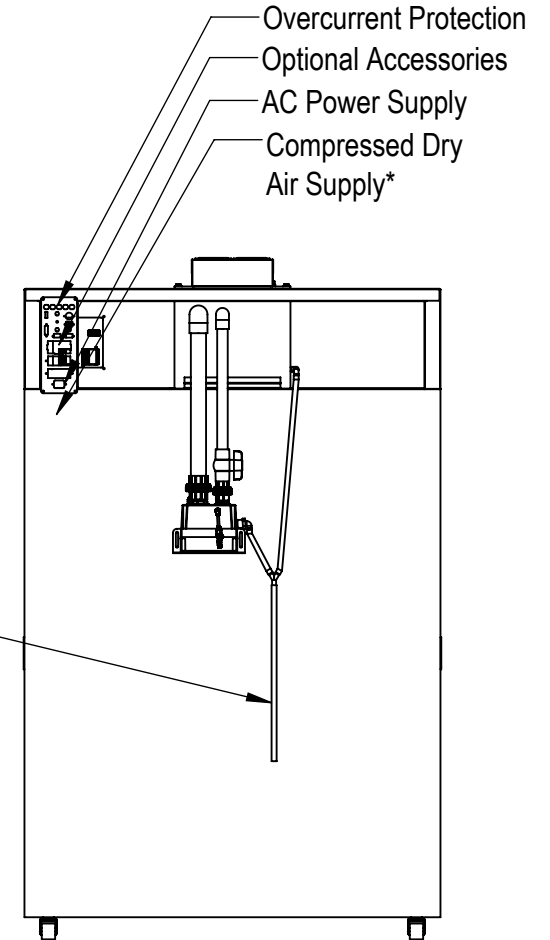

* Optional Accessory