

BUILT-IN UNDERCOUNTER FREEZER

Series Overview

The built-in undercounter freezer features a microprocessor temperature controller and display, this allows for precise temperature control, verification and recovery versus mechanical style thermostats. Models are designed with "front-breathing" ventilation which eliminates the need for clearance around the top and sides of the unit. *Periodic manual defrosting is required

BIUF-0420

One solid swing door chamber designed for maximum capacity while still allowing passage through most commercial doorways.



The Premier Built-in Undercounter Refrigerators and Freezers take a large step forward in performance from past general purpose units; offering a digital temperature display and alarm module coupled with a microprocessor temperature controller.



Performance

Unit comes standard with a temperature range of -15° C to -25° C Manual defrost. Products designed to operate in ambient room temperatures not to exceed 75° F / 50% RH.

Control System

All series models come standard with a digital microprocessor temperature controller providing a readout of actual and set-point values. This chamber comes with audible/visual alarms, high and low temperature alarms with remote alarm contacts.

Warranties

These chambers come with a two year parts and labor warranty.

Construction

Freezer is constructed of powder coated exterior.

- two fixed shelves
- one solid swing door, right hinged
- Magnetic door gasket for positive seal with keyed door lock and recessed door handle
- Leveling legs
- Probe access port (3/8")
- High density urethane foam cabinet and door insulation
- HFC-free refrigerant (R600a), foam insulation and packaging
- Exterior dimensions: 23.75" W x 24.5"D x 33.38"H
- Shipping weight: 132 lbs
- Voltage: 115 / 60 / 1.5 Amps, 1/8 HP
- Energy consumption: 0.97 kWh/day
- UL/C-UL listed
- Pyxis®, Omnicell® and AcuDose RX® compatible
- Energy Star Certified

Built-In Undercounter Refrigerator Technical Drawings

Front View

Side View

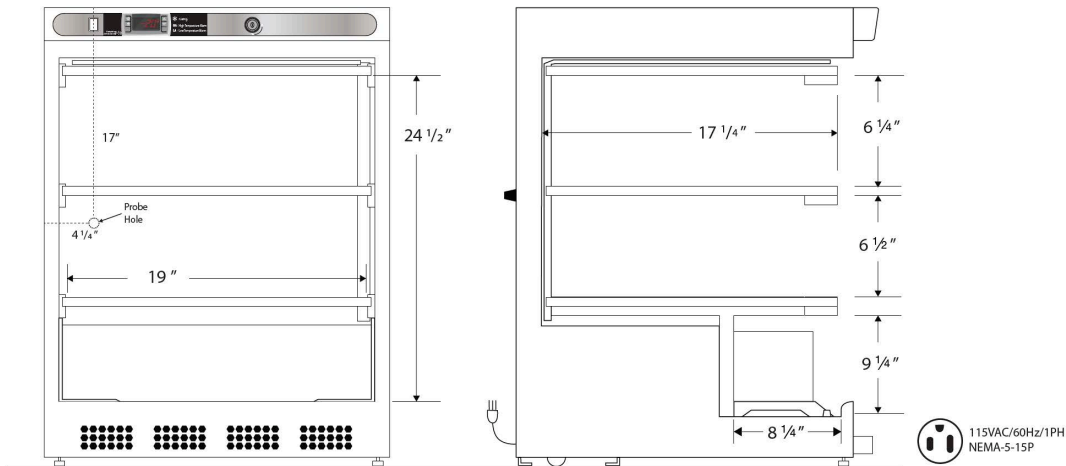

Cu. Ft	Defrost	Door	Int Door	Shelves	Interior Dim.			Refrigerant	H.P.	Amps	Weight
					W"	D"	H"				
4.2	Manual	1 Solid (Reversible)	0	2 Fixed	19	17 1/4	24 1/2	R600a	1/8	1.5	100 lbs.

Note: Interior dimensions are estimates and subject to change without notice

Front View

Side View

Top View

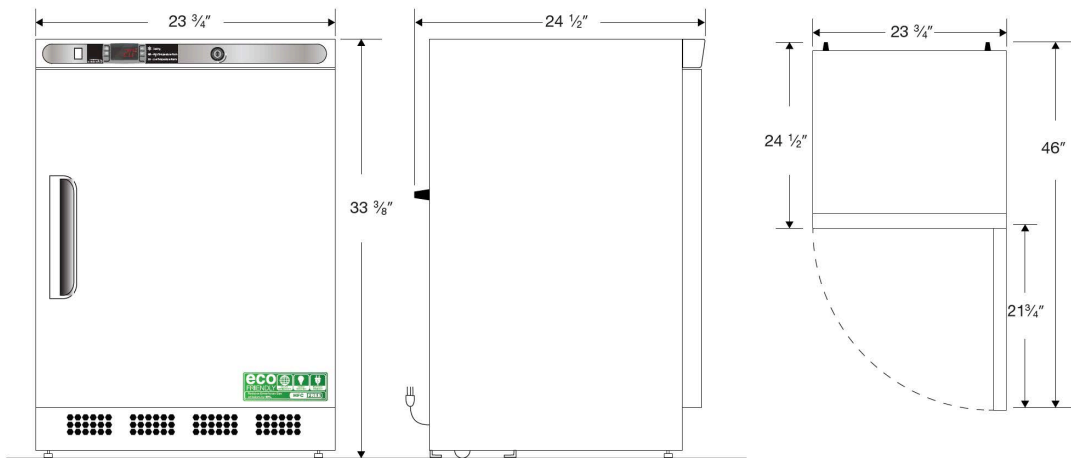

115VAC/60Hz/1PH
NEMA-5-15P

Cu. Ft	Defrost	Door	Int Door	Shelves	Interior Dim.			Refrigerant	H.P.	Amps	Weight
					W"	D"	H"				
4.2	Manual	1 Solid (Reversible)	0	2 Fixed	23 3/4	24 1/2	33 3/8	R600a	1/8	1.5	100 lbs.