

FZ055 STABILITY FREEZER CHAMBERS

FZ Series Overview

The FZ series laboratory freezer chambers are designed for performance specifications exceeding FDA and ICH requirements. The FZ series freezer chambers comes standard with the following performance: Solid-State Temperature Control. Autodefrost. Standard Microprocessor Controller with PID, Autotuning, programmable alarms (hi/lo), ability to ramp/soak, process variable and setpoint variable offset, dual display of actual temperature and setpoint temperature (process variable and setpoint variable). Controls are able to be quickly exchanged for future upgrades or repair.

FZ030

The FZ030 is a single-door stability freezer chamber.

FZ055

The FZ055 is a two-door stability freezer chamber.



Featured photo is the FZ055 two-door stability freezer chamber open door view to show adjustable internal racks.



Featured photo is the FZ055 two-door stability freezer chamber closed door view.



FZ SERIES: STABILITY FREEZER CHAMBERS

Reliable Cooling Redundancy

Each FZ series freezer includes multiple, independent thermoelectric cooling units. The 7 year warranty on cooling components and the ability of our chambers to maintain temperature, even if the chamber suffers multiple failures, is unmatched by any other refrigeration-based chamber.

Quiet Operation

The FZ series freezers utilize quiet, highly efficient DC fans.

Greatly Reduced Direct and Indirect Energy Loads

The FZ Series freezers utilize less energy than comparable incubators and introduce less impact upon building cooling systems. This efficiency "dual benefit" allows our chambers to be located in spaces unsuitable for other chambers.

Options Available

Chart Recorder
Data Logger

Widely Proven, Non-Proprietary Controllers

Standard controllers for the FZ Series are manufactured by Fuji Electric and are ideal for laboratory freezer. Unlike many proprietary controllers, this controller is commercially available and proven in tens of thousands of installations. Standard functions include: autotuning, fuzzy logic, PID control, programmable alarms, calibration capability, offset capability, etc. A touchscreen control interface is optional. Other controller manufacturers are also supported (Watlow, Allen-Bradley etc.)

Services and Warranties

We offer 24 hour technical support throughout the lifetime of your freezer. In addition to standard warranties, we also offer extended warranties for cooling components, parts and labor. We also provide qualifications, validations and preventive maintenance services at an additional cost. Please ask for a quote.

FZ055 Stability Freezer Chamber Specifications (ambient 21° C)

Performance	Standard	Customized Options
Temperature Range	-23° C to 50° C	Available
Ambient Temperature	21° C ± 3° C	Available
Temperature Control	± 0.2° C	Available
Temperature Uniformity	± 0.8° C	Available
Control Resolution	0.1° C	Available
Temperature Sensor	NIST Traceable PT 100 RTD Class A	Available

Control System	Standard	Customized Options
Controller	Microprocessor based PID	West EC-44, Future Design Touchpad + More
Control Readout	Actual and Set-Point Values	Trending, Duty Cycle
Calibration Correction Capability	Actual and Set-Point Values	Available
Uniformity Off Set	Standard 0.1 Resolution	Available
Alarm	Audible and Visual	Text, Email, Web Server, Remote Access
Alarm Type	Deviation in 0.1° C with Delay	Absolute 0.1 Resolution with Delay
Remote Monitoring	Available	Dry Alarm Contact, RS 485 & Analog Output
Password Protection	Numeric	Numeric, Alpha Numeric
Audit Trail	N/A	Available
Universal Power Supply for Monitoring	N/A	Available

Construction	Standard	Customized Options
Exterior	Stainless Steel Door & Front, Aluminum Sides	Stainless Steel Door, Front & Sides
Interior	Aluminum Side Walls & Back, Stainless Steel Floor & Ceiling	Stainless Steel Side Walls, Back, Floor, Door Liner & Ceiling
Shelving	3 Gray PVC Coated, Adjustable 1" Increments, Supports Up to 150 lbs of Evenly Distributed Weight	Stainless Steel, Chrome Plate or Custom
Casters	2.75" Total Weight Capacity is 300 lbs per Castor, Not Including the Weight of the Chamber	5" Casters or Seismic Legs

Capacity & Dimensions	US Standard	Metric
Interior Capacity	46.6 ft ³	1320 liters
External Dimensions	52.88" W x 35.81" D x 80.5" H	134.3 cm W x 90.95 cm D x 204.47 cm H
Internal Dimensions	47.5" W x 29" D x 58.5" H	120.65 cm W x 73.66 cm D x 148.59 cm H
Shelf Dimensions	22.25" W, 26.25" D	54.61 cm W x 66.68 cm D
Crated Weight	455 lbs	551 kg

Electrical	US Standard	International
Voltage	115v / 60HZ	230 / 50 / 1
RLA	4	5.8 With Step Down Transformer
Cord Length	7 ft	9 ft

FZ055 Stability Freezer Chamber Technical Drawings

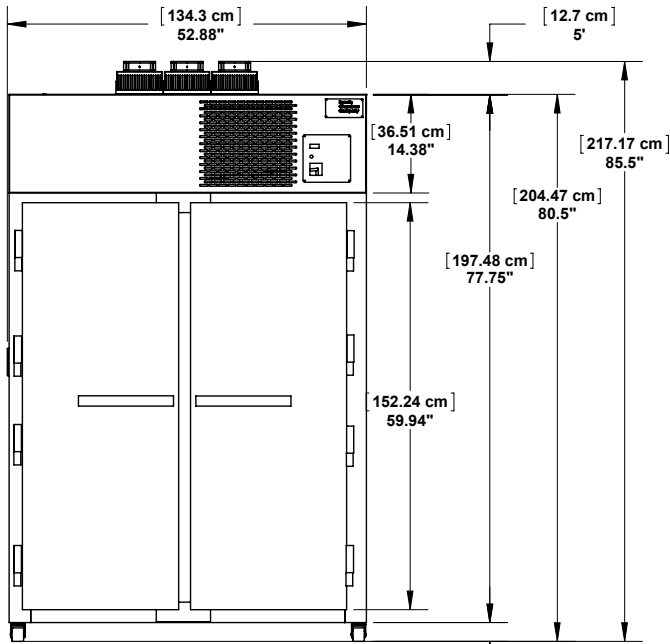

Front View

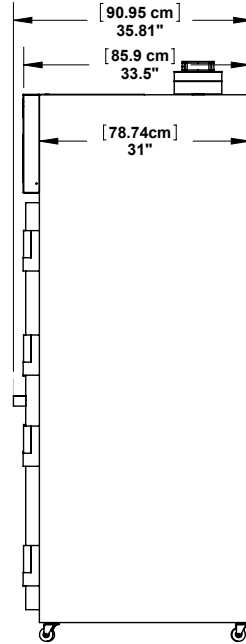

Side View

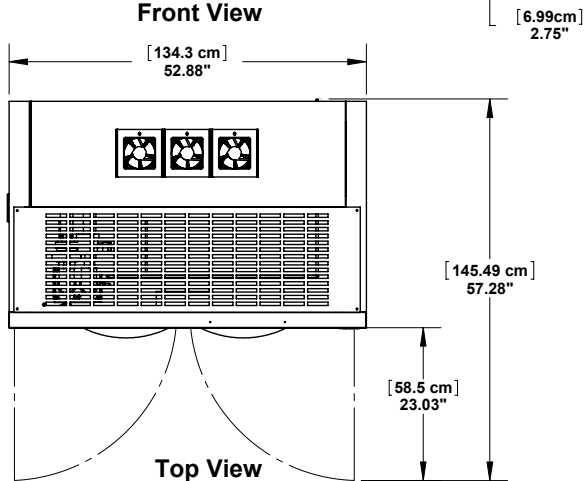

Top View

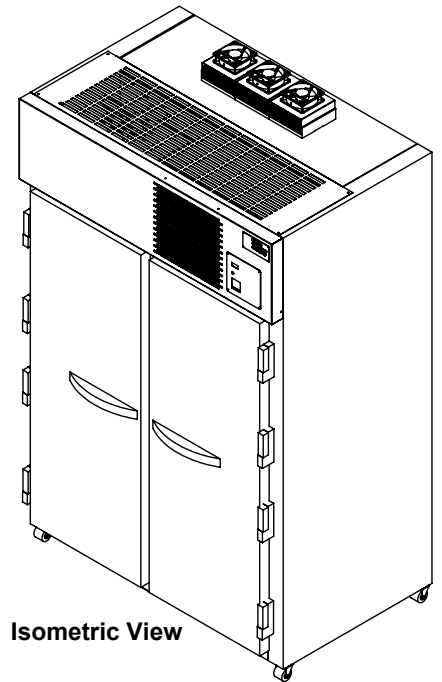

Isometric View