

FS030 STABILITY FREEZER CHAMBER

FS Series Overview

The FS Series is a top selling stability freezer chamber very common in laboratories.

FS030

The FS030 is a single-door stability freezer chamber.

FS055

The FS055 is a 2-door stability freezer chamber.



Featured photo is the FS030 single-door stability freezer chamber open door view to show adjustable internal racks.



Featured photo is the FS030 single-door stability freezer chamber closed door view.



FS SERIES: STABILITY FREEZER CHAMBERS

Temperature Range

The FS series offers a temperature range of -5° C to -23° C

Quiet Operation

The FS series freezers utilize quiet, highly efficient DC fans.

Widely Proven, Non-Proprietary Controllers

Standard controllers for the FS Series are manufactured by Fuji Electric and are ideal for laboratory freezer. Unlike many proprietary controllers, this controller is commercially available and proven in tens of thousands of installations. Standard functions include: autotuning, fuzzy logic, PID control, programmable alarms, calibration capability, offset capability, etc. A touchscreen control interface is optional. Other controller manufacturers are also supported (Watlow, Allen-Bradley etc.)

Options Available

Chart Recorder
Data Logger

Services and Warranties

We offer technical support throughout the lifetime of your freezer. In addition to standard warranties, we also offer extended warranties for cooling components, parts and labor. We also provide qualifications, validations and preventive maintenance services at an additional cost. Please ask for a quote.

Refrigeration System

The FS Series provides an oversized and balanced, environmentally friendly R404A refrigeration system, epoxy coated evaporator, large evaporator and coil heater permit for a short defrost cycle. Along with an automatic evaporator fan morto to delay frost during defrost.

FS030 Stability Freezer Chamber Specifications (ambient 21° C)

Performance	Standard	Customized Options
Temperature Range	-5° C to -23° C	Available
Ambient Temperature	21° C ± 3° C	Available
Temperature Control	± 0.2° C	Available
Temperature Uniformity	± 0.8° C	Available
Control Resolution	0.1° C	Available
Temperature Sensor	NIST Traceable PT 100 RTD Class A	Available

Control System	Standard	Customized Options
Controller	Microprocessor based PID	West EC-44, Future Design Touchpad + More
Control Readout	Actual and Set-Point Values	Trending, Duty Cycle
Calibration Correction Capability	Actual and Set-Point Values	Available
Uniformity Off Set	Standard 0.1 Resolution	Available
Alarm	Audible and Visual	Text, Email, Web Server, Remote Access
Alarm Type	Deviation in 0.1° C with Delay	Absolute 0.1 Resolution with Delay
Remote Monitoring	Available	Dry Alarm Contact, RS 485 & Analog Output
Password Protection	Numeric	Numeric, Alpha Numeric
Audit Trail	N/A	Available
Universal Power Supply for Monitoring	N/A	Available

Construction	Standard	Customized Options
Exterior	Stainless Steel Door & Front, Aluminum Sides	Stainless Steel Door, Front & Sides
Interior	Aluminum Side Walls & Back, Stainless Steel Floor & Ceiling	Stainless Steel Side Walls, Back, Floor, Door Liner & Ceiling
Shelving	3 Gray PVC Coated, Adjustable 1" Increments, Supports Up to 150 lbs of Evenly Distributed Weight	Stainless Steel, Chrome Plate or Custom
Casters	2.75" Weight Capacity is 300 lbs Per Castor, Not Including the Weight of the Chamber	5" Casters or Seismic Legs

Capacity & Dimensions	US Standard	Metric
Interior Capacity	24 ft ³	619 liters
External Dimensions	27.75" W x 35.81" D x 80.5" H	70.485 cm W x 90.95 cm D x 204.47 cm H
Internal Dimensions	22.5" W x 29" D x 58.5" H	57.15 cm W x 73.66 cm D x 148.59 cm H
Shelf Dimensions	22.25" W x 26.25" D	54.61 cm W x 66.68 cm D
Crated Weight	455 lbs	206 kg

Electrical	US Standard	International
Voltage	115v / 60HZ	230 / 50 / 1
RLA	4	5.8 With Step Down Transformer
Cord Length	7 ft	9 ft



FS030 Stability Freezer Chamber Technical Drawings

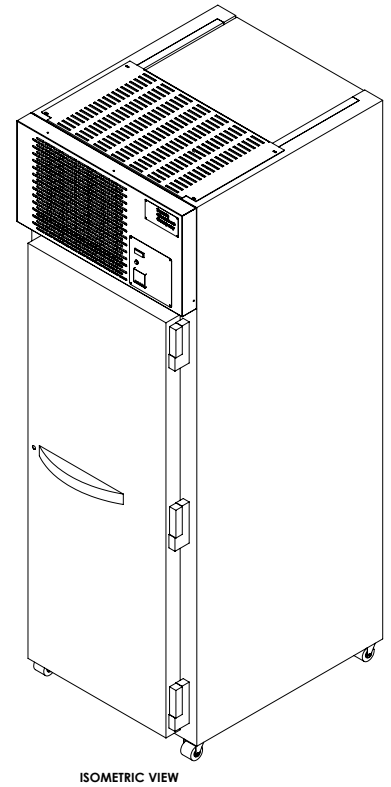
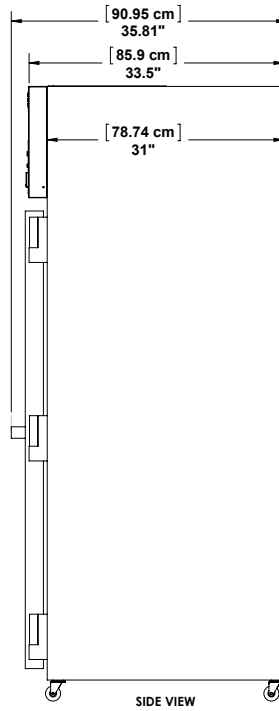
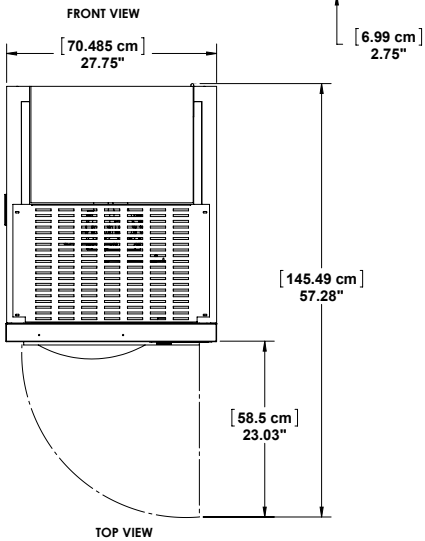
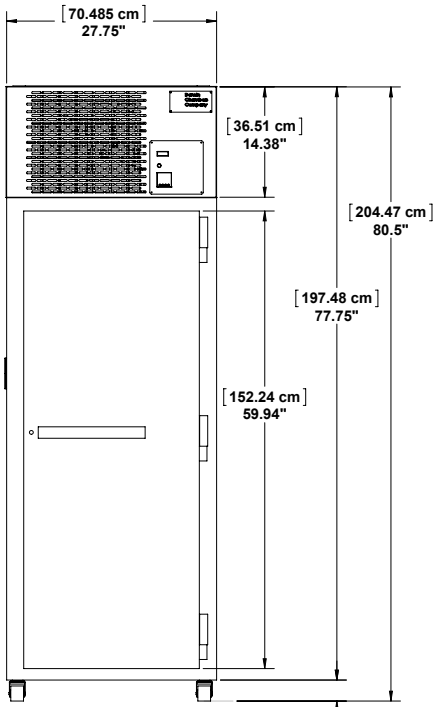

ISOMETRIC VIEW